

Hall B Solenoid and Torus Health Report (Sep 2017 to April 2018)

Pablo Campero

Detector Support Group

04/11/2018

Contents

- I. Overview
- II. Technical Specifications
- III. Torus Trips
- IV. Torus Controls and Monitoring Systems (CMS)
 - i. Instrumentation Issues
 - ii. Out of Plane (OOP) forces due to Interaction with Solenoid
 - iii. Cryogenics Monitoring System
- V. Solenoid Trips
- VI. Solenoid CMS
 - i. Instrumentation Issues
 - ii. Cryogenics Monitoring System
- VII. Solenoid Quench Detection Issues
- VIII. Torus/Solenoid Spares
- IX. Upcoming Tasks – Summer 2018
- X. Conclusion

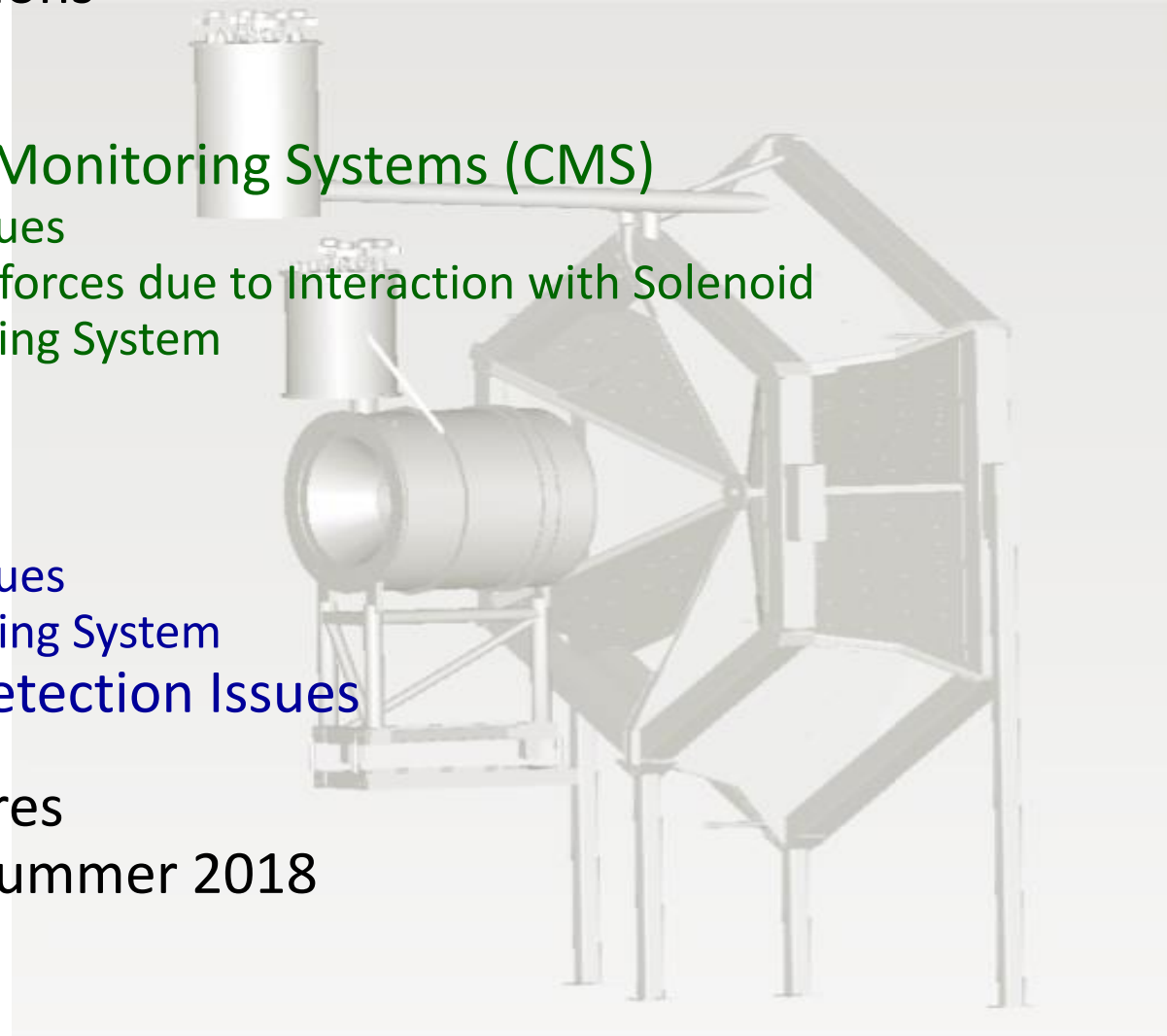

I. Overview

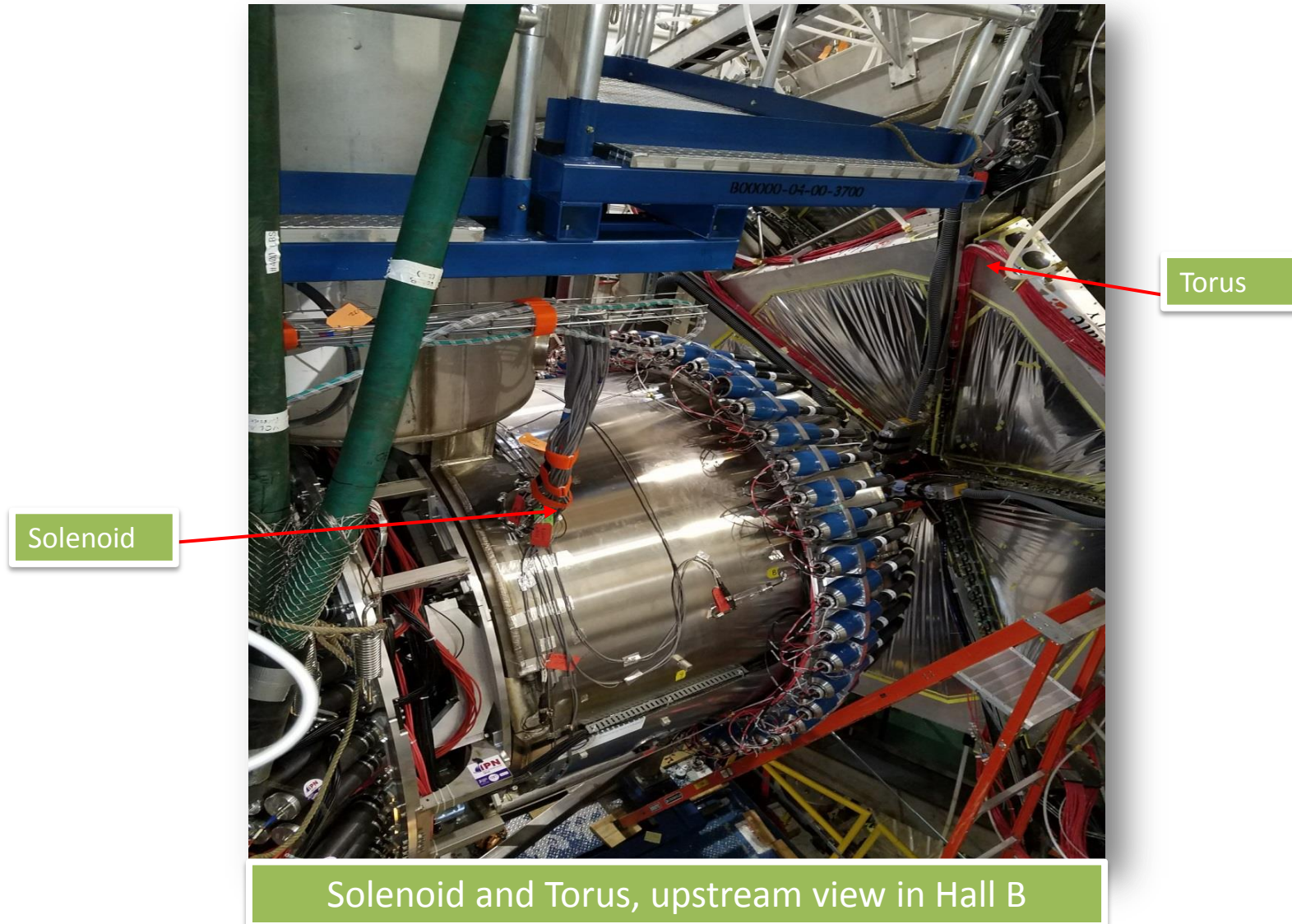

II. Technical Specifications of Torus and Solenoid

| Feature | Torus | Solenoid |
|---------------------------------|--|--|
| Number of Coils | 6 | 5 |
| Coil structure | Double pancake potted in aluminum case | Layer wound |
| Warm bore Ø (mm) | 124 | 780 |
| Total weight (Kg) | 25,500 | 18,880 |
| Number of turns per pancake | 117 | N/A |
| Number of turns per coil | 2 x 117 = 234 | 1392 |
| Number of turns in main coils | N/A | 3704 (2 x 840 + 2 x 1012) |
| Conductor | SSC outer dipole cable soldered in 20 mm x 2.5 mm Cu channel | SSC outer dipole w 17mm x2.5mm Cu channel |
| Turn-to-turn insulation | 0.003" E-Glass Tape ½ Lap | 0.004" Glass Tape ½ Lap |
| Nominal current (A) | 3770 | 2416 |
| Ampere turns (-) | 882,000 | N/A |
| Peak field (T) | 3.58 | 6.56 |
| Central field (T) | N/A | 5.0 |
| Peak field location | Inner turn near warm bore, adjacent to cooling tube | Inner turn near warm |
| B-symmetry | Yes | Yes |
| ∫Bdl @ nominal current (Tm) | 2.78 @ 5°, 0.54 @ 40° | 7.0 |
| Inductance (H) | 2 | 5.89 |
| Stored energy (MJ) | 14.2 | <20 |
| Quench protection/dump resistor | Hard wired quench detector/0.124 Ω dump resistor | Hard wired quench detector/0.124 Ω dump resistor |
| Coil cooling | Conduction cooled by supercritical Helium | Conduction cooled |
| Supply temperature (K) | 4.6 | 4.2 |
| Heat shield cooling | LN ₂ thermo-siphon | N/A |

III. Torus Trips

➤ Two fast dump events :

1. Danfysik Magnet Power Supply (MPS) unable to ramp up over 1080 A
 - Incorrect installation of silicon controlled rectifier (SCR) found on 12/05/17)
2. PLC lost communications on 04/01/2018

➤ Ten controlled ramp down events :

1. Unstable cryogenics / ESR faults
2. Loss of communication with Fast-DAQ cRIO
3. Load cells over thresholds

III. Torus Trips

➤ Two fast dumps

| Period | Fast Dump | Date | Time | Trip Current [A] | Cause | Description | Notes |
|------------------------|-----------|------------|-------|------------------|-------|---|--|
| Solenoid Commissioning | 1 | 11/22/2017 | 11:53 | 1080 | MPS | Thermal breaker fault showed as internal interlock in MPS (Status2. B1 bit tripped) | Improper (polarity) installation of SCR in MPS caused trip. Water cooling system's hoses were missing. |
| Engineering Run | 0 | | | | | | |
| Physics Run | 1 | 4/1/2018 | 7:08 | 3766 | PLC | PLC Ethernet module fault/error. Lost communication due to unknown fault. | |
| Fast Dumps | 2 | | | | | | |

IV. Torus CMS

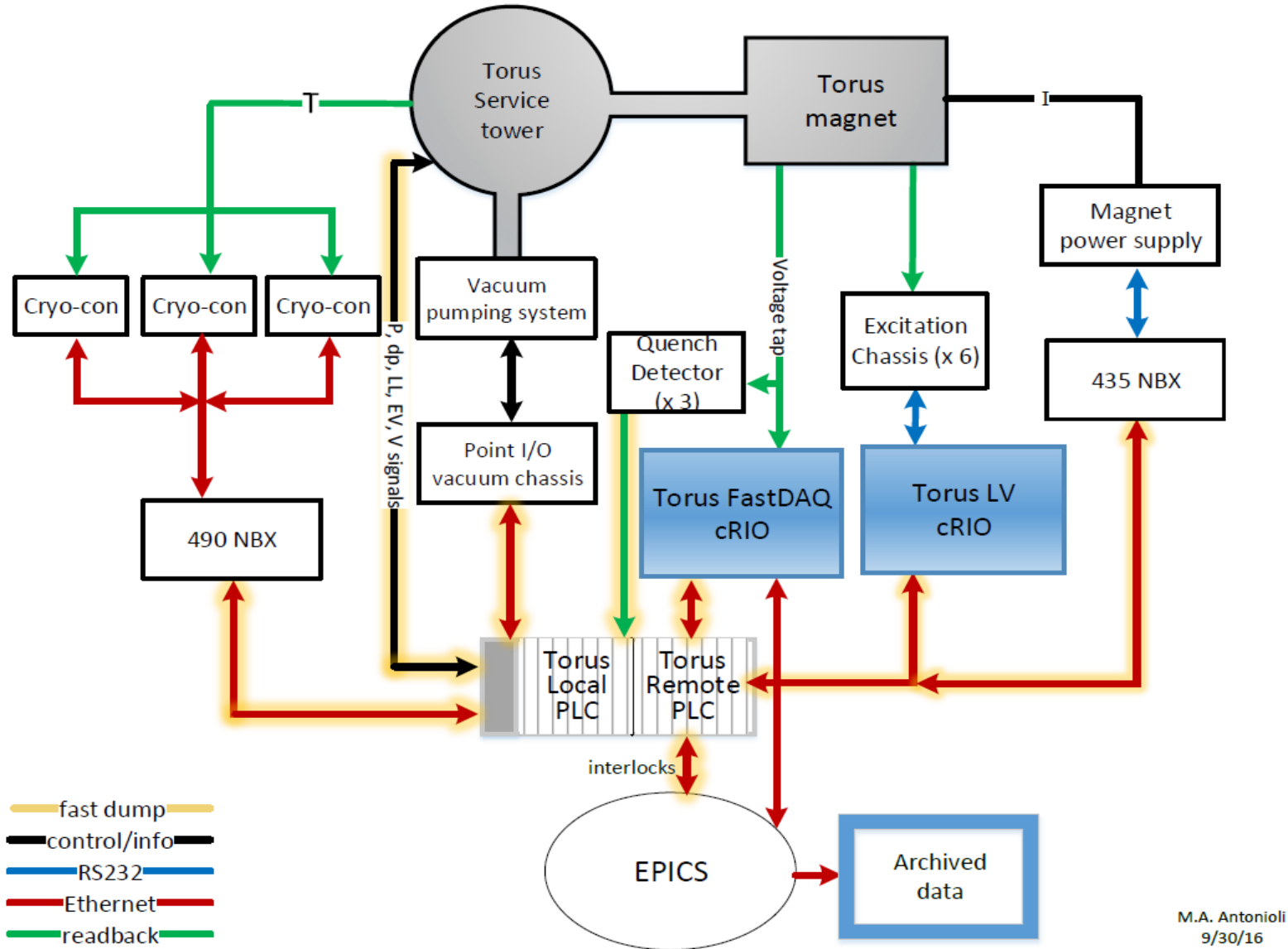

IV.i Torus Instrumentation Issues

- Fast-DAQ NI cRIO-9067/8 failures caused controlled ramp downs.
 - cRIO failures due to:
 - Inability to communicate with Hall B network
 - Communications possible in “safe mode”; however, LabVIEW program not available in safe mode
 - LabVIEW code missing after cRIO’s failure
 - No error log available, so failure reason unknown

- cRIO recovers by itself after power disconnection.
 - Takes >12 hours (Unexpected behavior)

Suggested purchase of two NI cRIO-9030s to be used as spares for either Solenoid or Torus.

IV.i Torus Instrumentation Issues

- Installed a Terminal Server to enable remote RS232 serial communication with Torus cRIOs
 - Routed cables between cRIOs on SFL2 and Moxa terminal server on SFL1
 - Console output enables easy access to debugging
 - Provides error log and special features

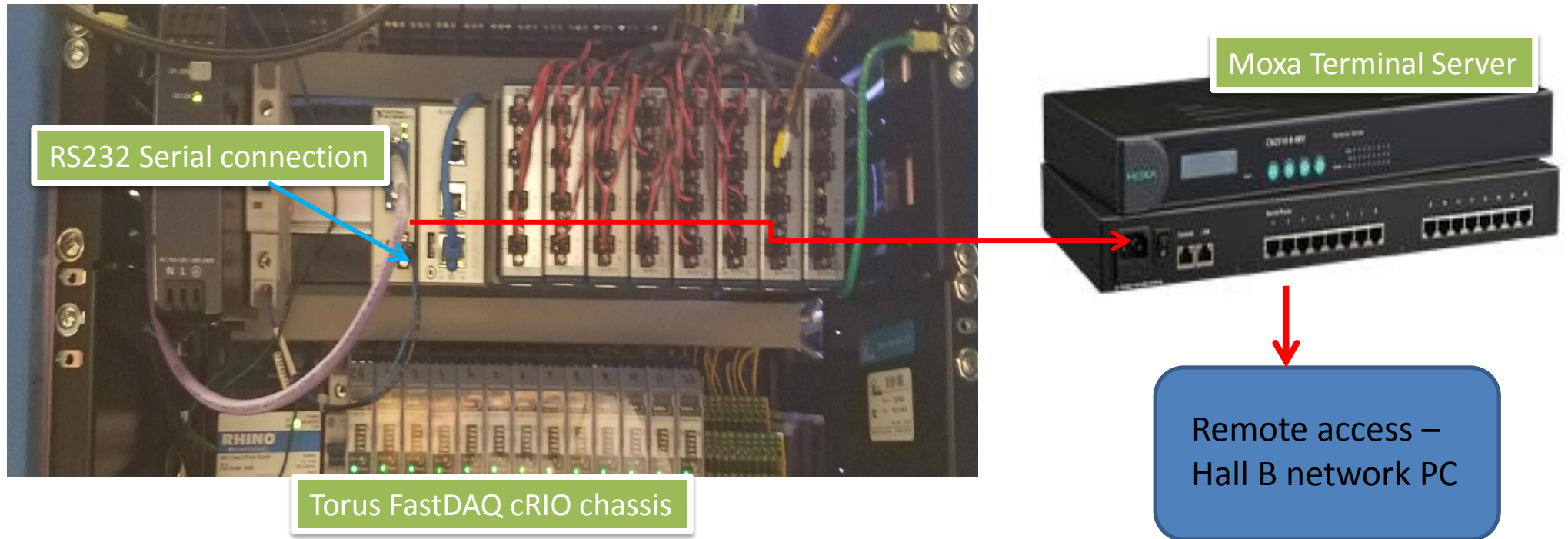

IV.i Torus Instrumentation Issues

- AB 1756 EN2T Ethernet/IP PLC module lost communication with Hall B network and generated Torus fast dump on 04/01/2018.
 - Local PLC controller complained about I/O Fault in Local:9 (Ethernet/IP module)
 - All remote modules had bad status
 - Ethernet/IP module showed error
 - " Cycle Power to Unit: Assert in File wrhvBspEventHandlers.cpp Line 83"
- Locally power-cycled PLCs' power supplies (local and remote chassis) to solve problem.



1756- EN2T Ethernet/IP PLC Module

IV.i Torus Instrumentation Issues

- Cernox temperature sensor was not reading on LV chassis #4
 - Swapped Q0131 PCB board with developmental LV chassis board
 - Failed Q0131 board had +12 V fuse shorted
 - Fuse replaced and board available as spare

- Load cell readouts over set thresholds caused controlled ramp down
 - Increased interlock delay thresholds
 - Increased alarm levels for load cells and strain gauges (axial and vertical supports)

- 60 mV spike signal at VT21 generated controlled ramp down when Torus was at 0 A
 - PLC logic changed to avoid ramp down when power supply is at 0 A
 - VT21 noise investigated
 - Verified wiring connections; no problems found

IV.i Torus Instrumentation Issues

- On 09/28/2017, SCR circuit overheated in Torus MPS
 - Thyristor (SCR) was not water-cooled as expected from factory setup
 - MPS cleaned and found residuals of machining (drilling, milling, cutting)
 - Danfisyk solution:
 - Provide new SCR
 - Install missed hoses to provide proper water cooling to SCR circuit
 - Install missed thermal switches/ temperature sensors with adaptors
- On 11/22/2017, Torus fast dump at 1080 A
 - Previous SCR replacement was installed backwards (anode, cathode incorrect positions), which led to ramping issues and internal trips on MPS

SCR circuit overheated in Torus MPS
Insulation burned

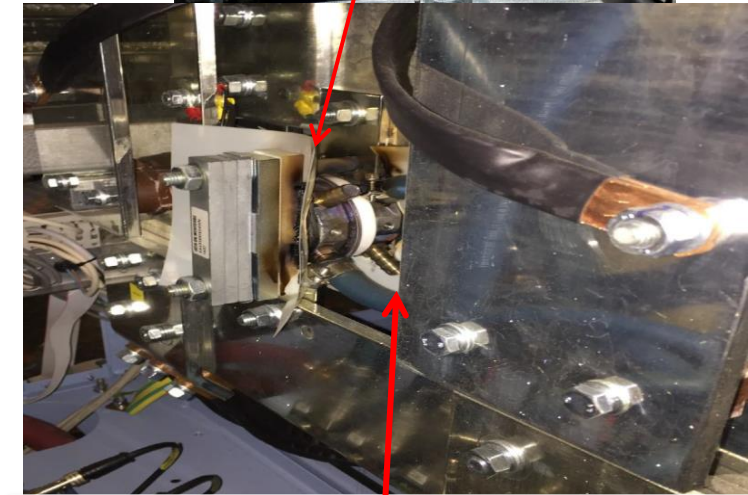

Disconnected hoses on SCR at Torus MPS



Microscopic view of
residual materials
found in Torus MPS

IV.ii Torus – Out Of Plane Forces

- Load cell sensors are part of out of plane support mounted in Torus
- Four load cells are symmetrically installed in each of six coils in Torus
- Torus has 24 load cells for monitoring out of plane forces

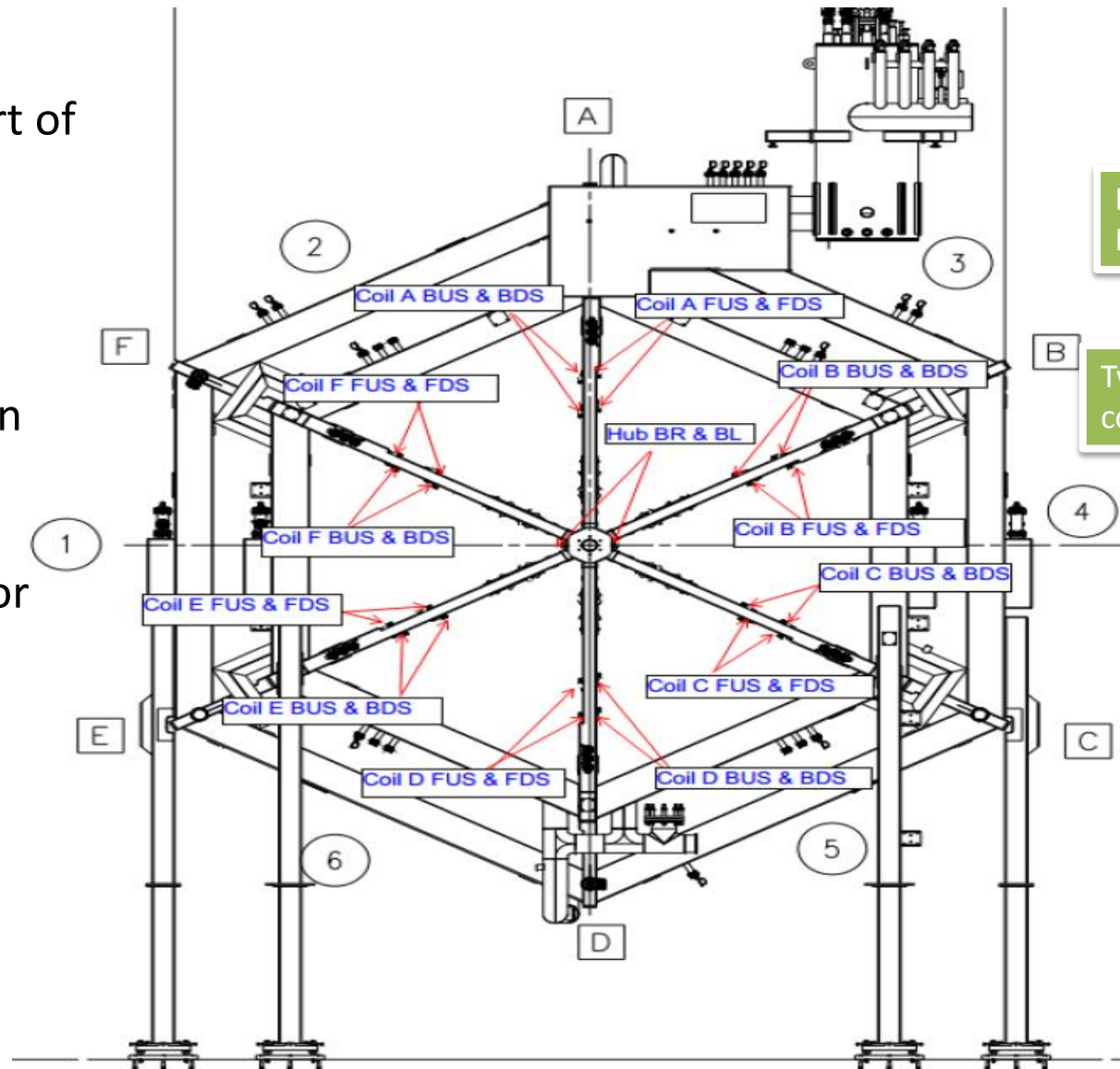

BDS = Back Downstream
FUS = Front Upstream

Two load cells installed at each face of coils (back and front)

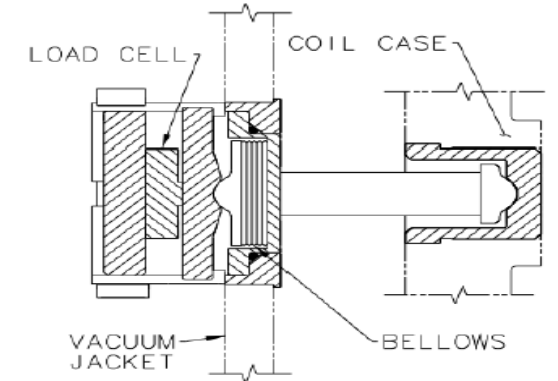

Coil out of plane support detail

IV.ii Torus – OOP Forces due to Interaction with Solenoid

| | | Current [A] | Polarity | Magnetic Field [T] | Date |
|-----------|---|----------------------------|-------------------------|-----------------------|---------------------|
| Solenoid | | 2416 | positive | 4.5 | 3/5/2018 |
| Torus | | 3770 | positive | 2 | |
| Load Cell | Total EM Force Description | Total EM Force Value [lbf] | Cooldown Baseline [lbf] | EM Differential [lbf] | EM Force Diff Limit |
| CCM_A | [CCMA_FUS + CCMA_FDS]-[CCMA_BUS + CCMA_BDS] | 288 | 18 | 270 | 1000 |
| CCM_B | [CCMB_FUS + CCMB_FDS]-[CCMB_BUS + CCMB_BDS] | 1271 | 573 | 698 | 1000 |
| CCM_C | [CCMC_FUS + CCMC_FDS]-[CCMC_BUS + CCMC_BDS] | 800 | 516 | 284 | 1000 |
| CCM_D | [CCMD_FUS + CCMD_FDS]-[CCMD_BUS + CCMD_BDS] | -788 | 61 | -849 | 1000 |
| CCM_E | [CCMD_FUS + CCMD_FDS]-[CCMD_BUS + CCMD_BDS] | 1088 | 1490 | -402 | 2000 |
| CCM_F | [CCMF_FUS + CCMF_FDS]-[CCMF_BUS + CCMF_BDS] | 810 | 1349 | -539 | 2000 |

Data entries in table are averages for OOP force values during time shown in red box

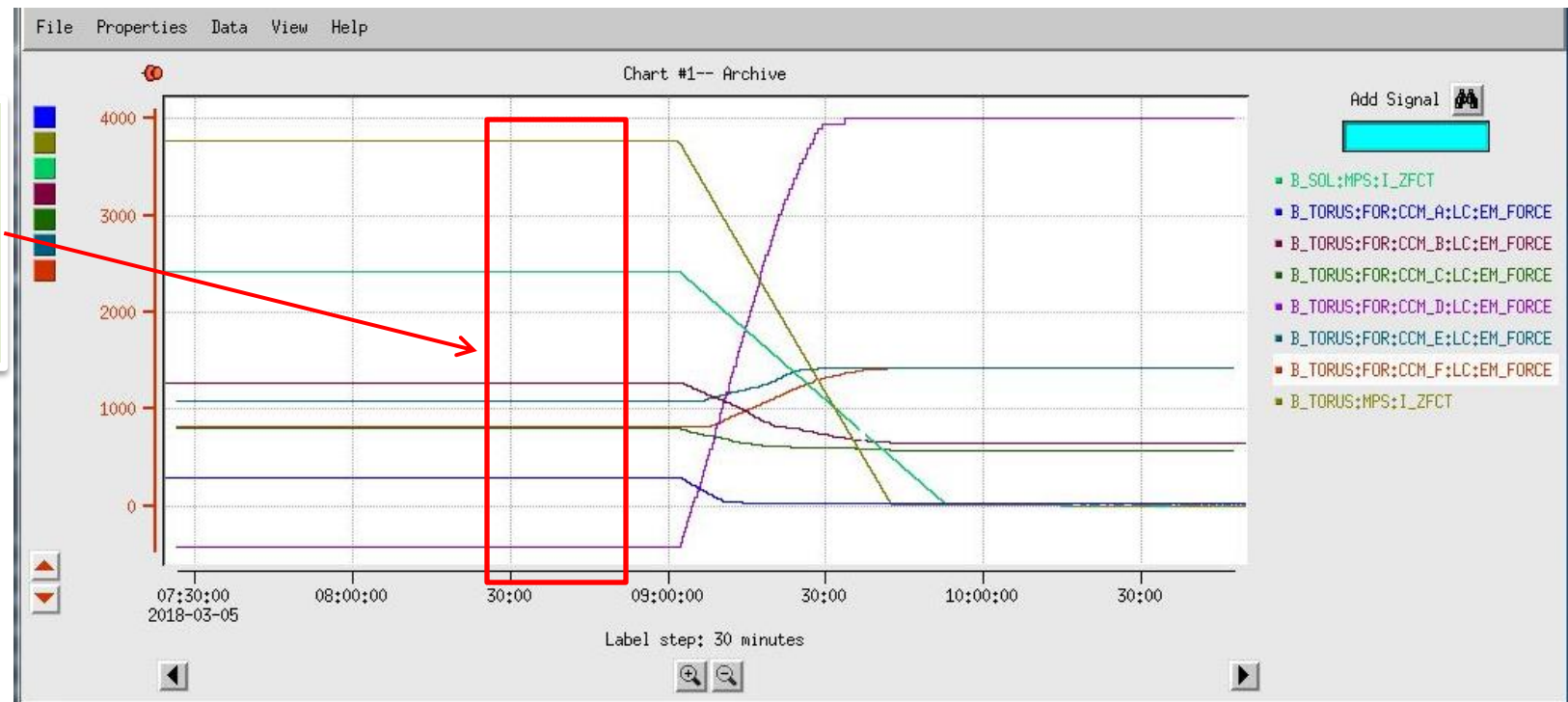

IV.ii Torus – OOP Forces due to Interaction with Solenoid

| Solenoid | | Current [A] | Polarity | Magnetic Field [T] | Date |
|-----------|---|----------------------------|-------------------------|-----------------------|---------------------|
| Solenoid | | 2416 | positive | 4.47 | 2/18/2018 |
| Torus | | -3780 | negative | -1.99 | |
| Load Cell | Total EM Force Description | Total EM Force Value [lbf] | Cooldown Baseline [lbf] | EM Differential [lbf] | EM Force Diff Limit |
| CCM_A | [CCMA_FUS + CCMA_FDS]-[CCMA_BUS + CCMA_BDS] | 28 | 18 | 10 | 1000 |
| CCM_B | [CCMB_FUS + CCMB_FDS]-[CCMB_BUS + CCMB_BDS] | 426 | 573 | -147 | 1000 |
| CCM_C | [CCMC_FUS + CCMC_FDS]-[CCMC_BUS + CCMC_BDS] | -12 | 516 | -528 | 1000 |
| CCM_D | [CCMD_FUS + CCMD_FDS]-[CCMD_BUS + CCMD_BDS] | 61 | 61 | 0 | 1000 |
| CCM_E | [CCMD_FUS + CCMD_FDS]-[CCMD_BUS + CCMD_BDS] | 1942 | 1490 | 452 | 2000 |
| CCM_F | [CCMF_FUS + CCMF_FDS]-[CCMF_BUS + CCMF_BDS] | 1569 | 1349 | 220 | 2000 |

Data entries in table are averages for OOP force values during time shown in red box

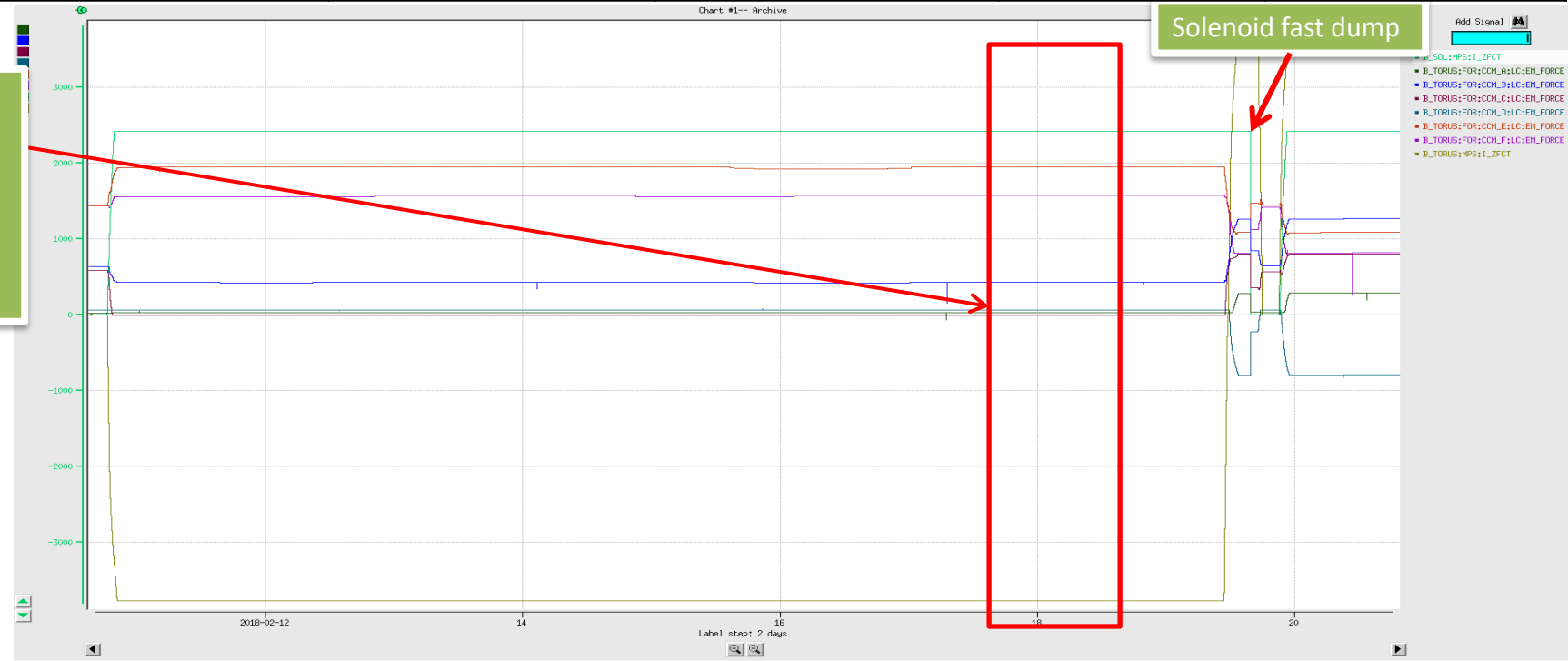

IV.ii Torus – OOP Forces due to Interaction with Solenoid

| | | Current [A] | Polarity | Magnetic Field [T] | Date |
|-----------------|---|----------------------------|-------------------------|-----------------------|---------------------|
| Solenoid | | -2416 | Negative | -4.48 | 1/23/2018 |
| Torus | | 2259 | Positive | 1.2 | |
| Load Cell | Total EM Force Description | Total EM Force Value [lbf] | Cooldown Baseline [lbf] | EM Differential [lbf] | EM Force Diff Limit |
| CCM_A | [CCMA_FUS + CCMA_FDS]-[CCMA_BUS + CCMA_BDS] | 30 | 18 | 12 | 1000 |
| CCM_B | [CCMB_FUS + CCMB_FDS]-[CCMB_BUS + CCMB_BDS] | 411 | 573 | -162 | 1000 |
| CCM_C | [CCMC_FUS + CCMC_FDS]-[CCMC_BUS + CCMC_BDS] | 121 | 516 | -395 | 1000 |
| CCM_D | [CCMD_FUS + CCMD_FDS]-[CCMD_BUS + CCMD_BDS] | 65 | 61 | 4 | 1000 |
| CCM_E | [CCMD_FUS + CCMD_FDS]-[CCMD_BUS + CCMD_BDS] | 1759 | 1490 | 269 | 2000 |
| CCM_F | [CCMF_FUS + CCMF_FDS]-[CCMF_BUS + CCMF_BDS] | 1556 | 1349 | 207 | 2000 |

Data entries in table are averages for OOP force values during time shown in red box

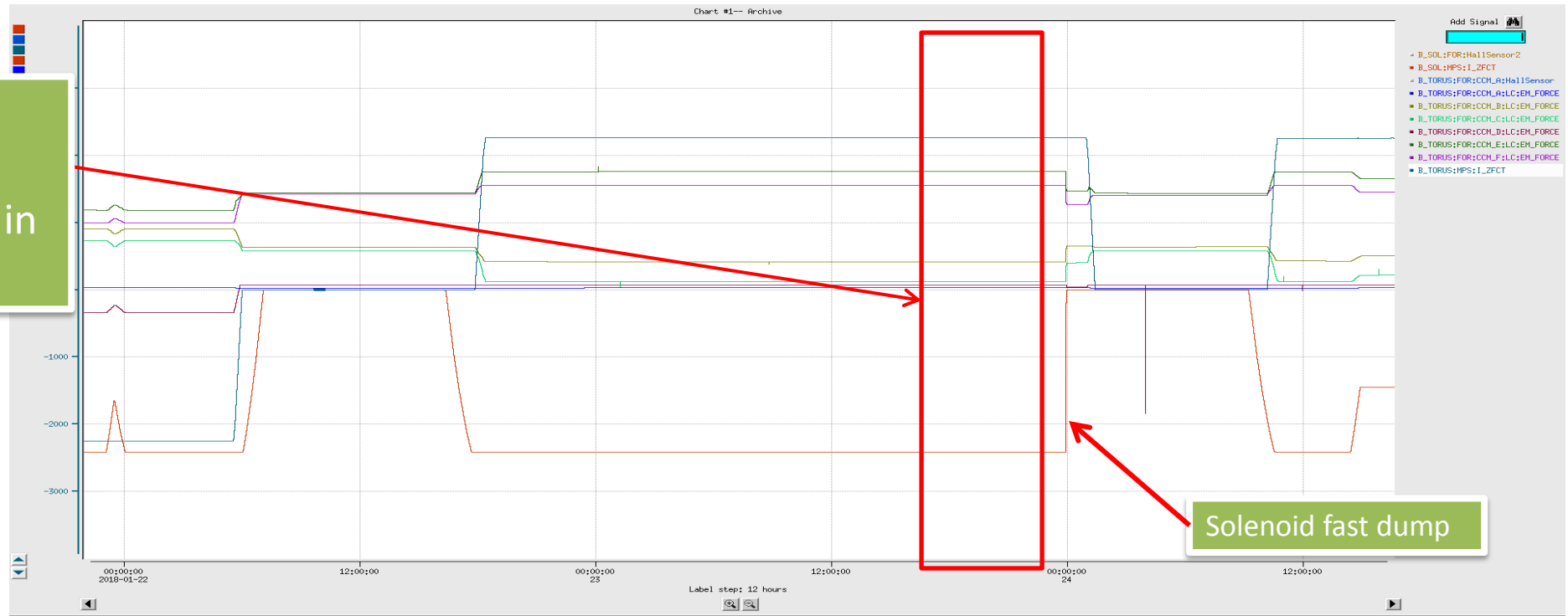

IV.iii Torus Cryogenics Monitoring

- Six of ten controlled ramp downs were generated by ESR trips and cryogenic variables (P, T, LL) over threshold conditions
- PID parameters that control valves and heater modified to stabilize cryo system
 - Tuning required to find most stable cryogenic conditions based on Solenoid heat loads
- Overall, cooldown recovers with no major problems after trips

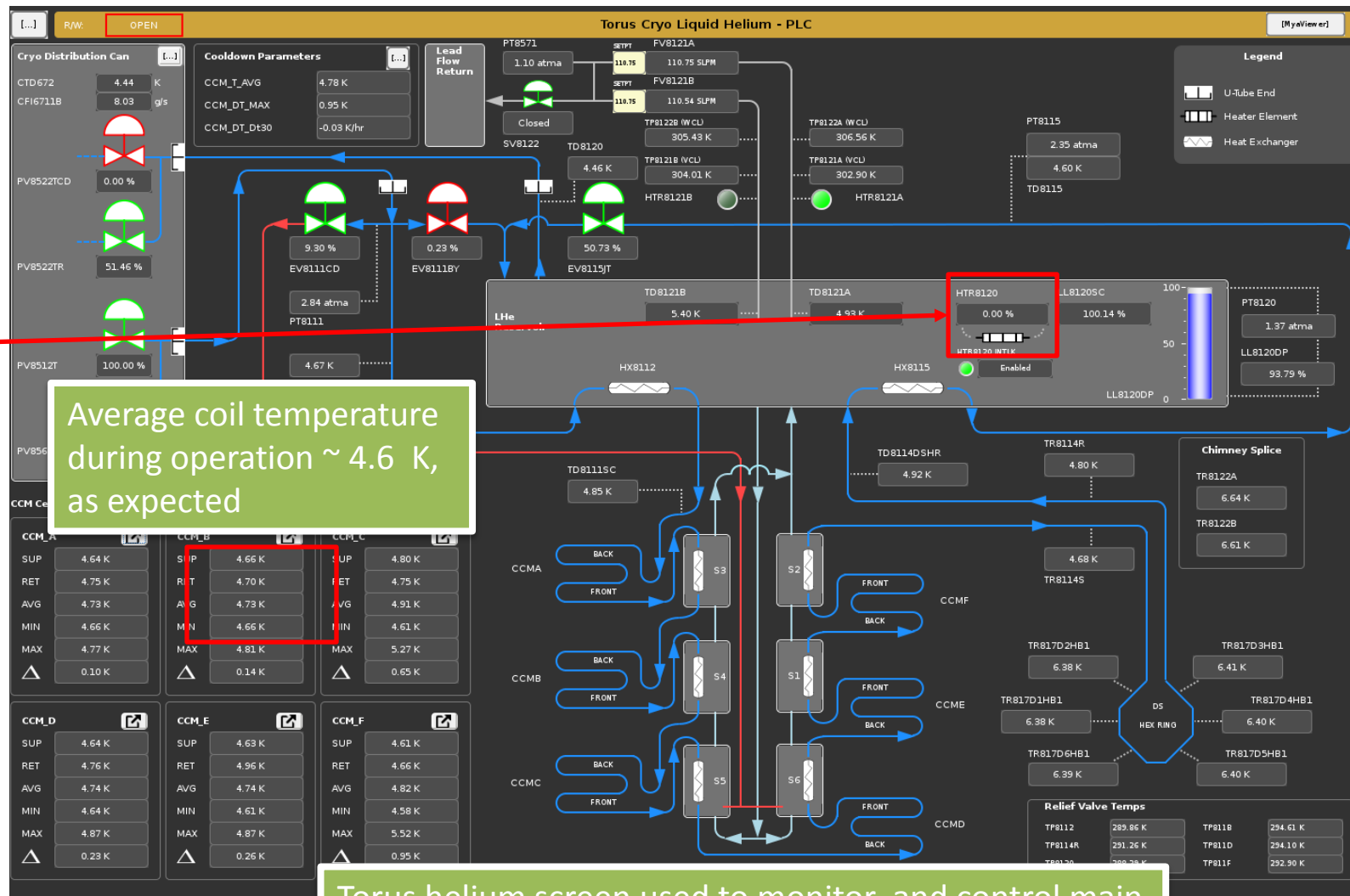

V. Solenoid Trips

Hall B - Solenoid Fast Dumps (Sep, 2017 to April,2018)

| Period | Fast Dump # | Date | Time | Trip Current [A] | Cause | VT combination | Description | Threshold | Time Delay | Notes |
|---------------|-------------|-----------|-------|------------------|------------|--|---|-----------|------------|--|
| Commissioning | 1 | 9/12/2017 | 14:47 | 932 | QD1 :Ch3 | VT15+VT16+VT17+VT18+VT19 | VT18 had voltage spike ~600 mV that generates VT8 (coil 3 quenching) went to ~ 2.3[V] | 60 mV | | |
| | 2 | 9/12/2017 | 17:27 | 1014 | QD1:Ch3 | VT15+VT16+VT17+VT18+VT19 | VT18 splice voltage spike ~125 [mV] which generated VT12 (coil 4 quenching) went to ~ 5.5 [V] | 60 mV | | On 09-15-2017, PLC became primary protection system for VT splices. Thresholds changed for QDs 1 and 2 (non coils VTs) and PLC comparators. QD VT splices thresholds raised from 60 mV to 750 mV and trigger window from 0 to 999 ms |
| | 3 | 9/13/2017 | 16:15 | 1035 | QD1:Ch1 | [VT11+VT12+VT13+VT14] - [VT5+VT6+VT7+VT8+VT9+VT10] | Differential of addition of all VT combinations in QD1:CH1 generated Fast dump | 60 mV | | |
| | 4 | 9/15/2017 | 9:07 | 1060 | QD1:Ch2 | [VT9+VT10+VT11+VT12+VT13+VT14]-[VT5+VT6+VT7+VT8] | Suspected VT8 (coil 3) | 60 mV | | |
| | 5 | 9/15/2017 | 11:39 | 1066 | QD1:Ch2 | [VT9+VT10+VT11+VT12+VT13+VT14]-[VT5+VT6+VT7+VT8] | Suspected VT8 (coil 3) | 60 mV | | Voltage noise of ~41 mV on QD1 (Ch1 and Ch2 associated with VT coils 1-5). Threshold raised from 60 mv to 100 mV. |
| | 6 | 9/15/2017 | 19:52 | 2148 | Cryogenics | N/A | Over temperature on VCLB. Temperatrue increased to > 14 K | 13.5 K | | To check coil VTs during fast dump, refer to: https://logbooks.jlab.org/entry/3484612 |

V. Solenoid Trips

| Hall B - Solenoid Fast Dumps (Sep, 2017 to April, 2018) | | | | | | | | | | |
|---|-------------|------------|-------|------------------|----------|--|---|-----------|------------|--|
| Period | Fast Dump # | Date | Time | Trip Current [A] | Cause | VT combination | Description | Threshold | Time Delay | Notes |
| Engineering Run | 7 | 12/12/2017 | 22:02 | 1208 | QD1: Ch3 | VT15+VT16+VT17+VT18+VT19 | VT18 had voltage spike ~175 mV | 750 mV | 999 ms | QD1:Ch4 VT combinations modified to cover only VT19 rather than VT17, VT18, VT19 |
| | 8 | 12/13/2017 | 9:49 | 1208 | QD1:Ch3 | | | | | Bad jumpered contact on VT panel switches; refer to: https://logbooks.jlab.org/entry/3503731 |
| | 9 | 12/14/2017 | 14:13 | 1208 | QD1: Ch3 | VT15+VT16+VT17+VT18+VT19 | VT18 had voltage spike of 170 mV | 750 mV | 999 ms | Voltage spike tripped QD1 interlock even when read value was lower than set threshold |
| | 10 | 12/16/2017 | 10:35 | 2416 | QD1:Ch1 | [VT11+VT12+VT13+VT14]- [VT5+VT6+VT7+VT8+VT9+VT10] | QD1:Ch1 lower which measure voltages in Coils 4 and 2 | 100 mV | 20 ms | Increased trip delay time thresholds for QD1: Ch1 and Ch2 to 100 ms |
| | 11 | 12/18/2017 | 9:01 | 1493 | QD2:Ch4 | VT15+VT16+VT17+VT18 | VT18 had voltage spike ~ 400 mV | 750 mV | | Noise along cable used for VT18 (150 mV). Cable consists of three separate, shielded, multi-conductors, none of them grounded. |
| | 12 | 1/23/2018 | 23:54 | -2416 | QD1:Ch1 | [VT11+VT12+VT13+VT14]- [VT5+VT6+VT7+VT8+VT9+VT10] | Suspected voltage increment across coils generated fast dump. Considered shift of coils as a cause. | 100 mV | 100 ms | Time delay thresholds for QD1: Ch1 and Ch2 were increased to 200 ms and all other QD Chs to 999 ms |

V. Solenoid Trips

| Hall B - Solenoid Fast Dumps (Sep, 2017 to April,2018) | | | | | | | | | | |
|--|-------------|-----------|-------|------------------|-------------------|---|---|--------------------|------------|---|
| Period | Fast Dump # | Date | Time | Trip Current [A] | Cause | VT combination | Description | Threshold | Time Delay | Notes |
| Phisycs Run | 13 | 2/19/2018 | 15:47 | 2416 | QD1:Ch3 / QD2:Ch4 | VT15+VT16+VT17+VT18+VT19/ VT15+VT16+VT17+VT18 | VT18 spiked to ~ 60 mV. Adding all VT values in: QD1:Ch3 ~ 155 mV and QD2:Ch4 ~80 mV | 1500 mV 1550 mV | 999 ms | Third time that voltage spike tripped QD1 interlock, even when read value was lower than set thresholds |
| | 14 | 4/1/2018 | 7:08 | 2416 | QD1:Ch1 | [VT11+VT12+VT13+VT14]- [VT5+VT6+VT7+VT8+VT9+VT10] | VT10 at coil 5 caused by Torus dump. VT10 voltage increased to~260 mV due to electromagnetic inductive coupling | 200 mV | 200 ms | Torus fast dump due to PLC ethernet module communication failure |
| | 15 | 4/9/2018 | 1:26 | 2416 | QD1:Ch1 | [VT11+VT12+VT13+VT14] - [VT5+VT6+VT7+VT8+VT9+VT10] | QD1:Ch1 lower tripped (LED indicator showed red light). SOE PLC module indicated QD Sum1 tripped first. Not sure which VT due to loss of Fast DAQ data. | -186 mV | 200 ms | No FastDAQ data recorded. Reason: soft IOCs were not reset after cRIO FastDAQ was swapped on 04/01/2018 |
| Total# of fast dumps | | 15 | | | | | | | | |

VI. Solenoid Control Systems

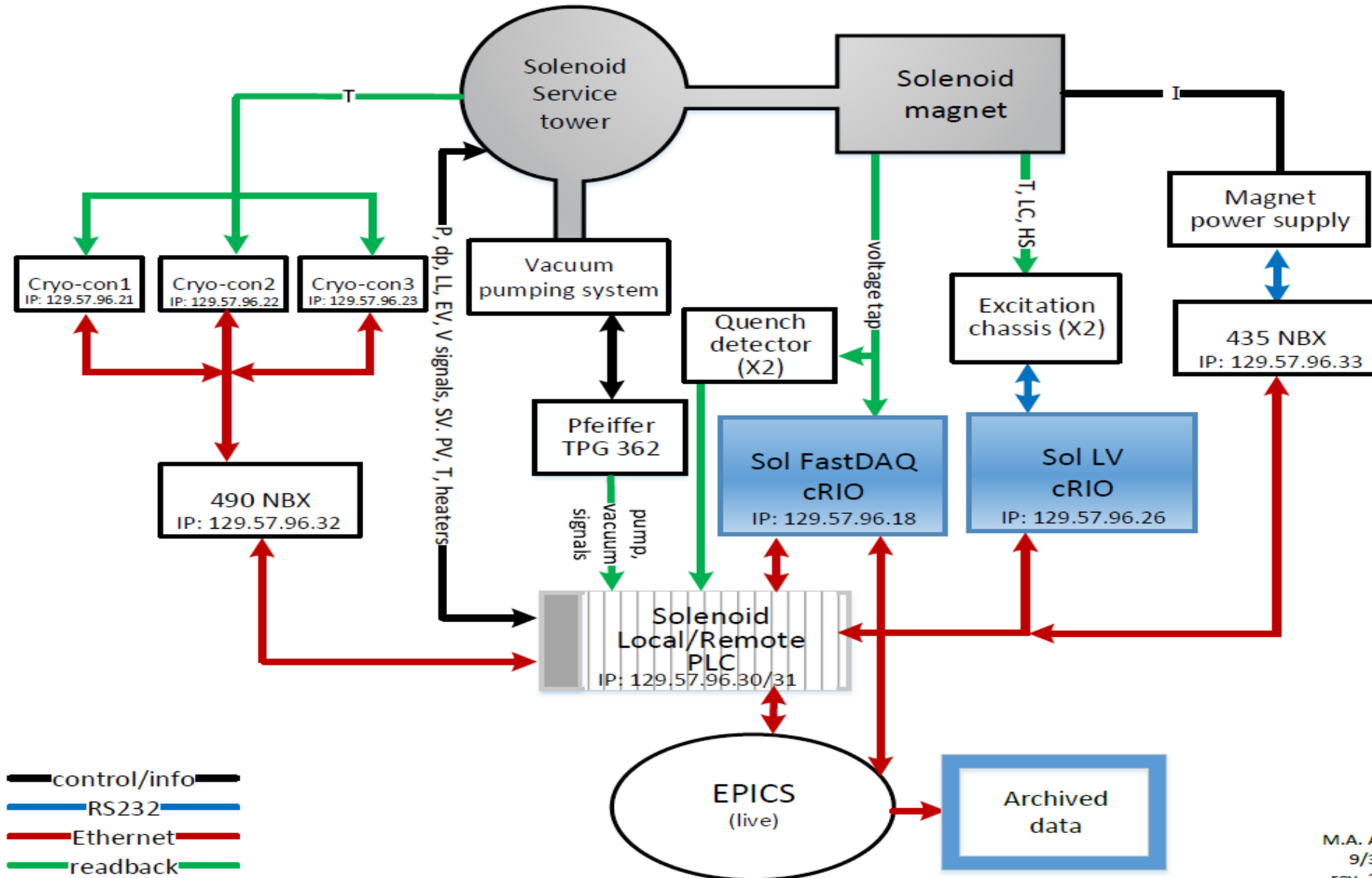

M.A. Antonioli
9/30/16
rev. 2/21/17

IV.i Solenoid Instrumentation Issues

- Installed Terminal Server to enable remote RS232 serial communication with Low Voltage cRIO and FastDAQ cRIO.
- FastDAQ NI cRIO-9067 presented the same faulty conditions as 9068 series used in Torus.
 - Three failures
 - No solution suggestions from NI support service
 - [Swapped FastDAQ NI cRIO-9067 with cRIO-9035](#)
- LV cRIO controller model: NI cRIO-9074 stopped sending data to PLC.
 - Happened twice during physics run (March 19 and April 17, 2018)

VI.i Solenoid Instrumentation Issues

- AB1756-SOE module unable to clear time stamp registers
 - PLC control logic could be improved by adding delay timers that allow at least 200 ms delay to reset fault
- Generated web page to convert RS-Logix timestamp format data to UNIX time
 - Web page saves time, allows prompt answers to determine first fault when Solenoid has fast dump
- PLC quench detection program modified to be primary protection system for quench events in Solenoid.
 - Due to several QD faults during commissioning, QD hardware made to be secondary protection system

IV.i Solenoid Instrumentation Issues

➤ Found dead sensors during commissioning:

- Three Cernox temperature sensors
- One Hall sensor

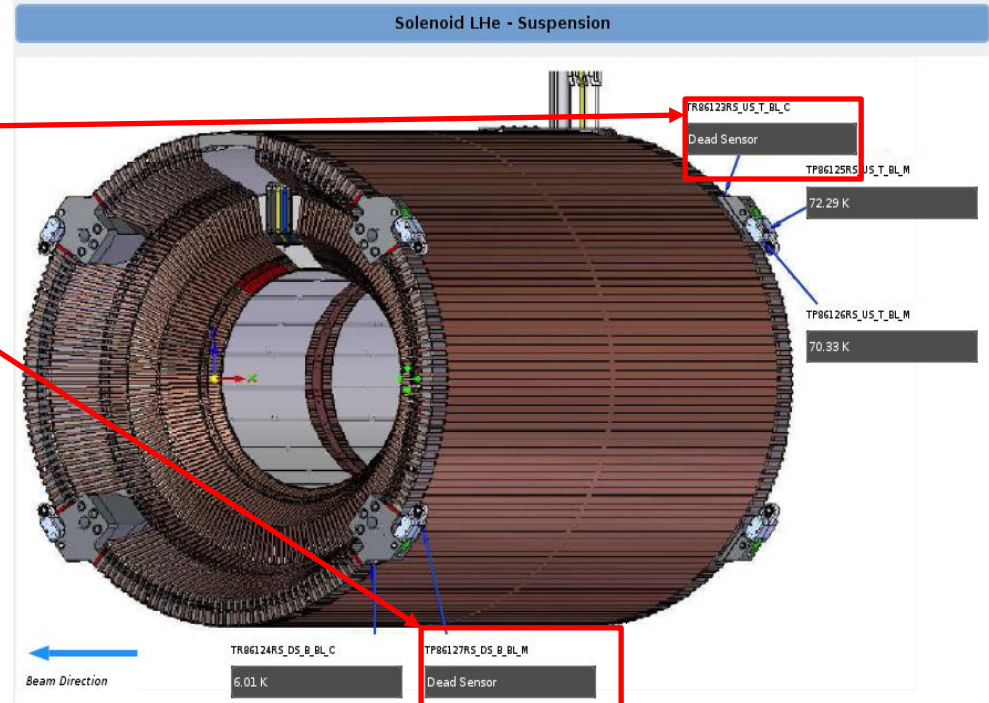
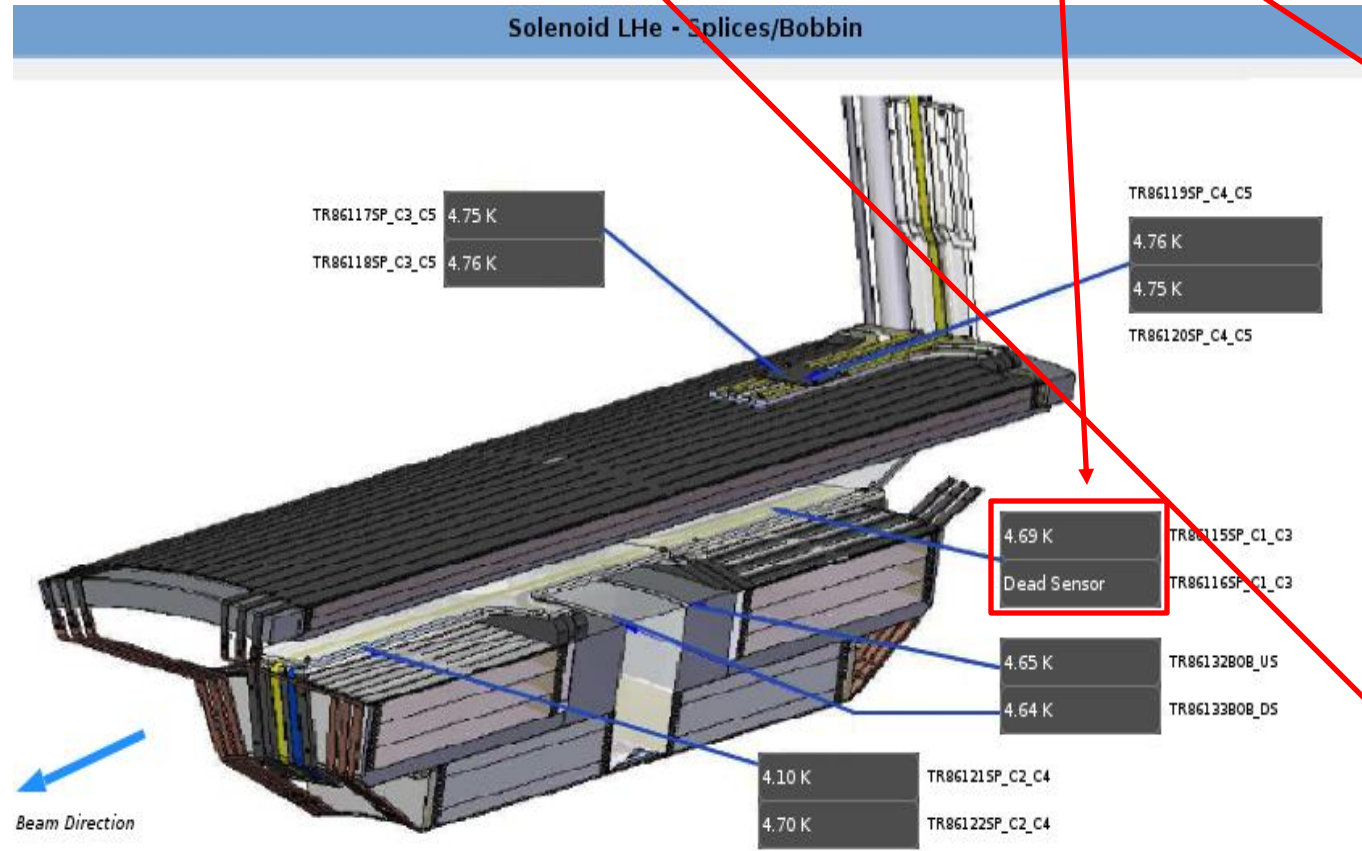

Solenoid MPS Control COMM ●

Turn OFF MPS

Setpoint: 2416.00 A

Slew: 273 mA/s

MAX (software): 2450.00 A

Current (MPS): 2405.46 A

Current (IDCCT1): 2418.25 A

Voltage: 1.56 V

Polarity: POSITIVE

Field Direction: D/S

Interlock Summary:

- Fast Dump
- MPS Internal
- Controlled Ramp

Hall Sensors (DS bore edge)

| | |
|-------------|-------------|
| HallSensor1 | Dead Sensor |
| HallSensor2 | 44746.11 G |
| HallSensor3 | 45324.03 G |

Reset PLC Interlocks

Reset MPS Interlocks

Reset Comms

IV.i Solenoid Instrumentation Issues

- Added 21 s delay to remove spurious trips from load cells interlock
- Removed load cell interlock that was generating fast dumps
 - Load cell interlock only available for controlled ramp down.
- Added missed components of water cooling system in MPS
 - After preventive inspection and issues presented in Torus MPS, hoses found to be missing in water cooling system
 - Installed missed thermal switches/temperature sensors with adaptors and hoses
- Found bad contacts in switches at VTs' panel
 - Bad switches jumpered out.

VI.ii Solenoid Cryogenics Monitoring System

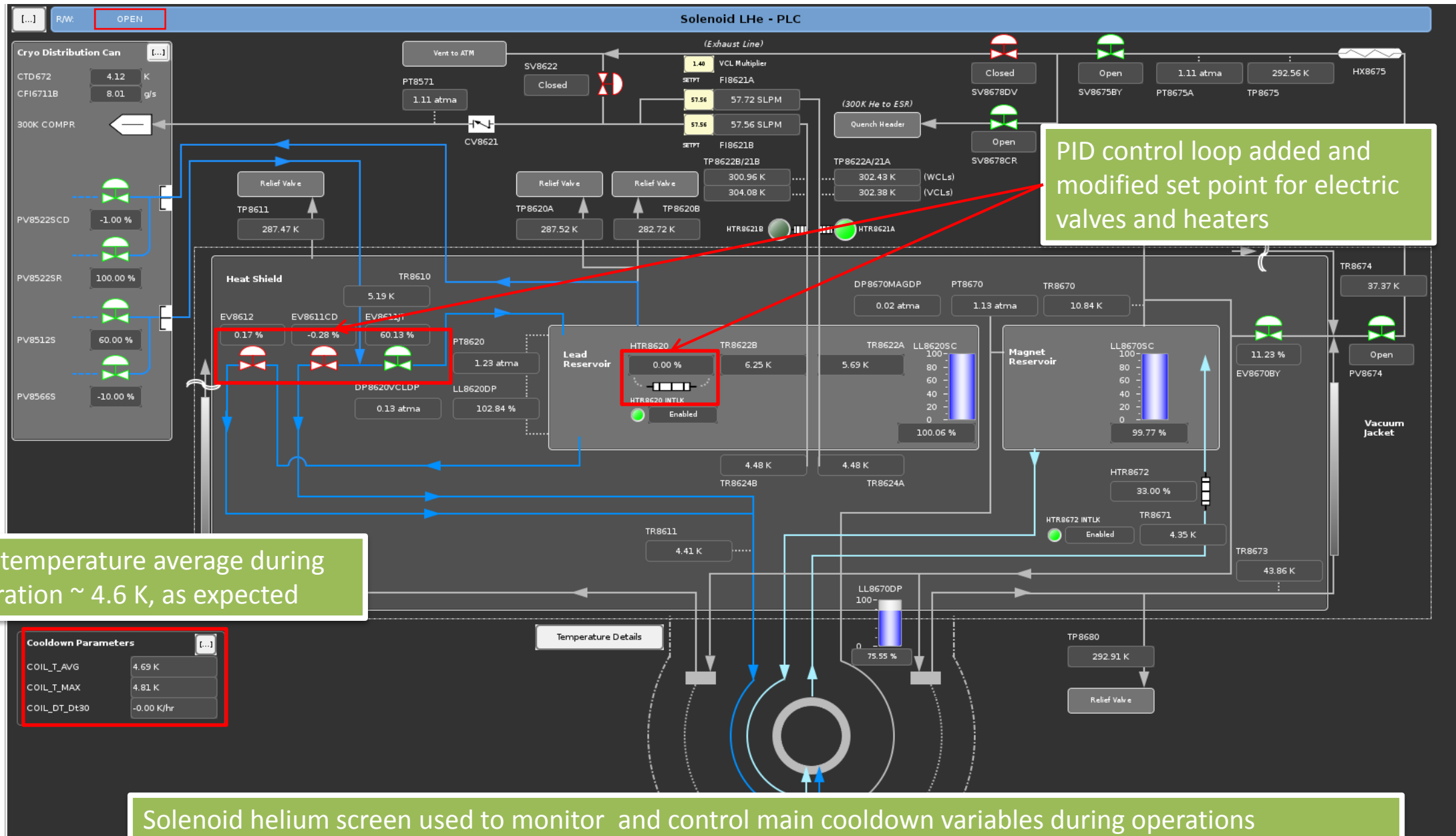

VII. Solenoid Quench Detection Issues

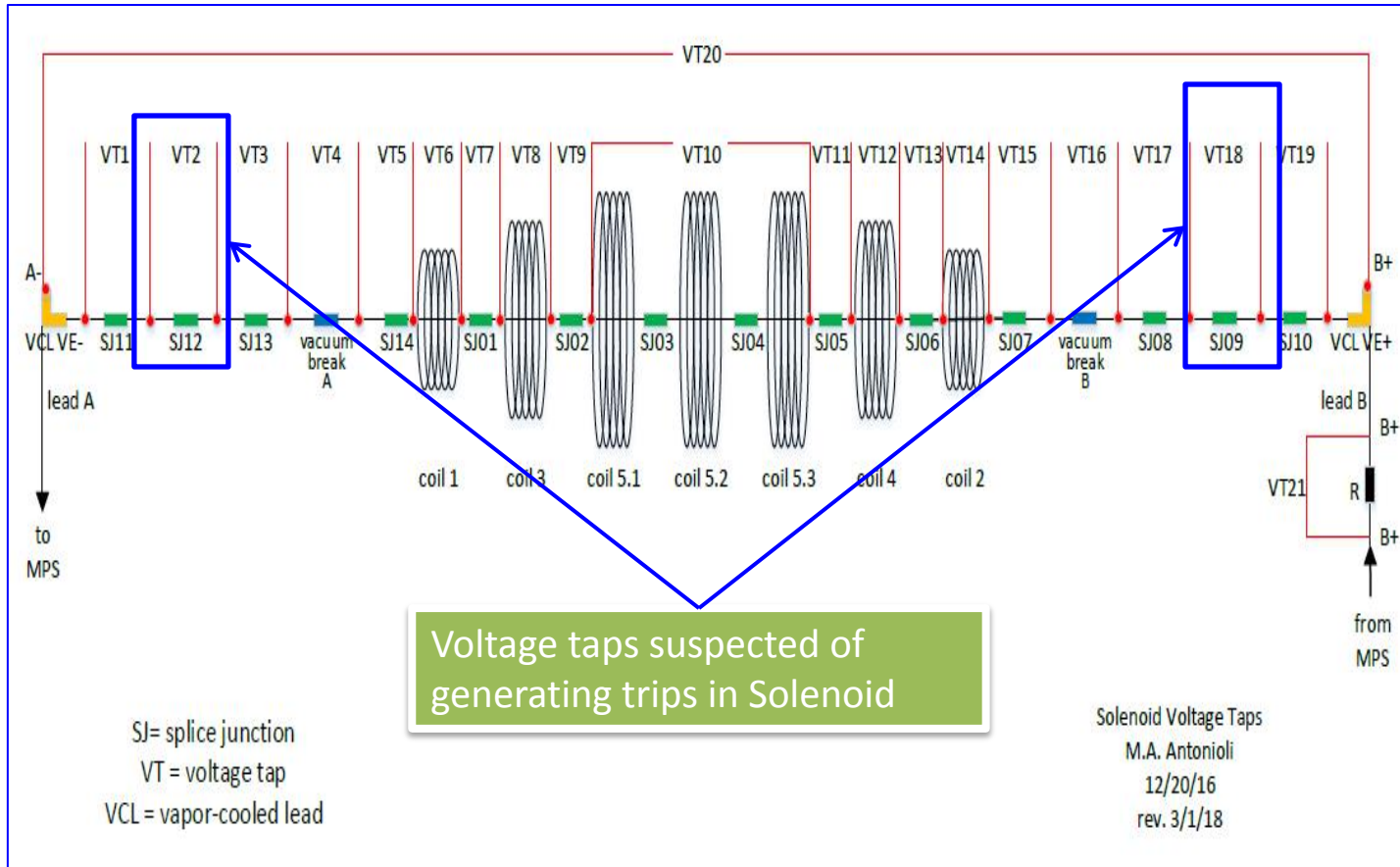

Solenoid Fast Dumps VS QD trips

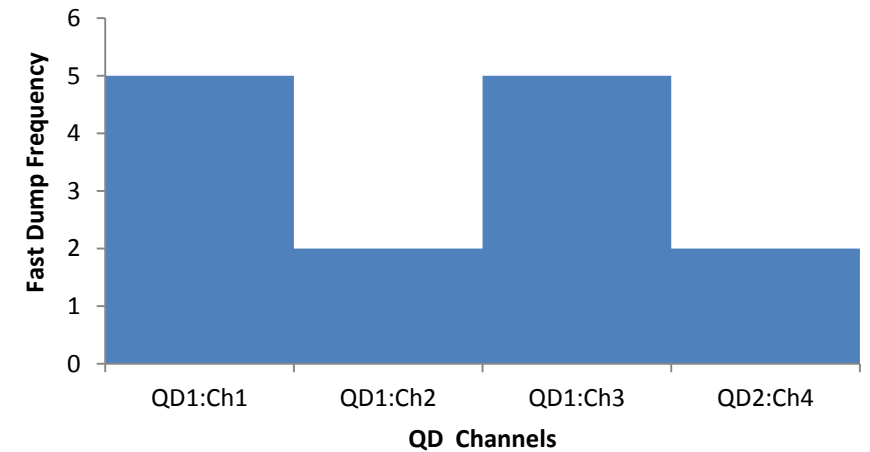

VII. Solenoid Quench Detection Issues

- Two scopes to connected to monitor QD2:ch4 as

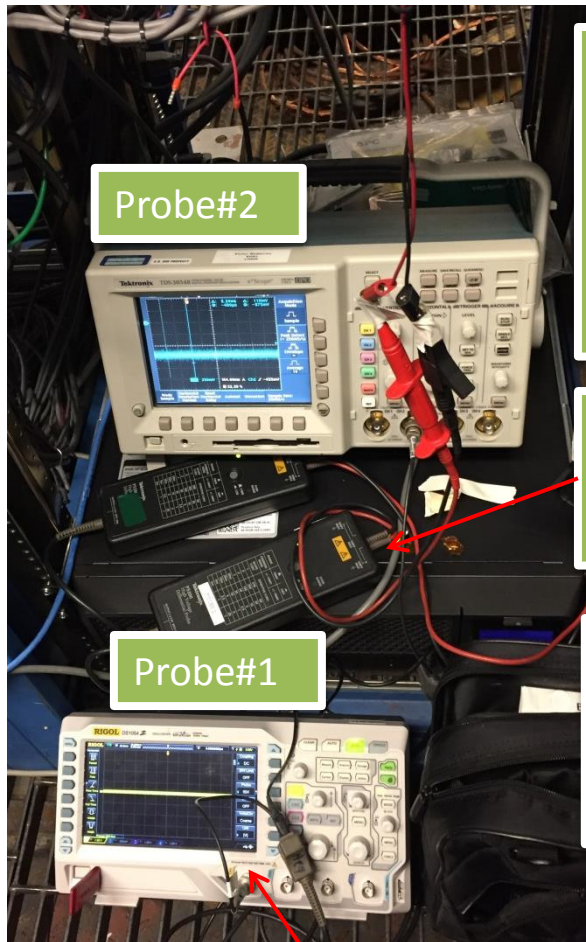

Probe #2 connected to monitor voltage spikes from Solenoid (to compare with FASTDAQ data)

Differential probes for diagnostic testing

Probe #1 connected to monitor voltage spikes generated internally in QD

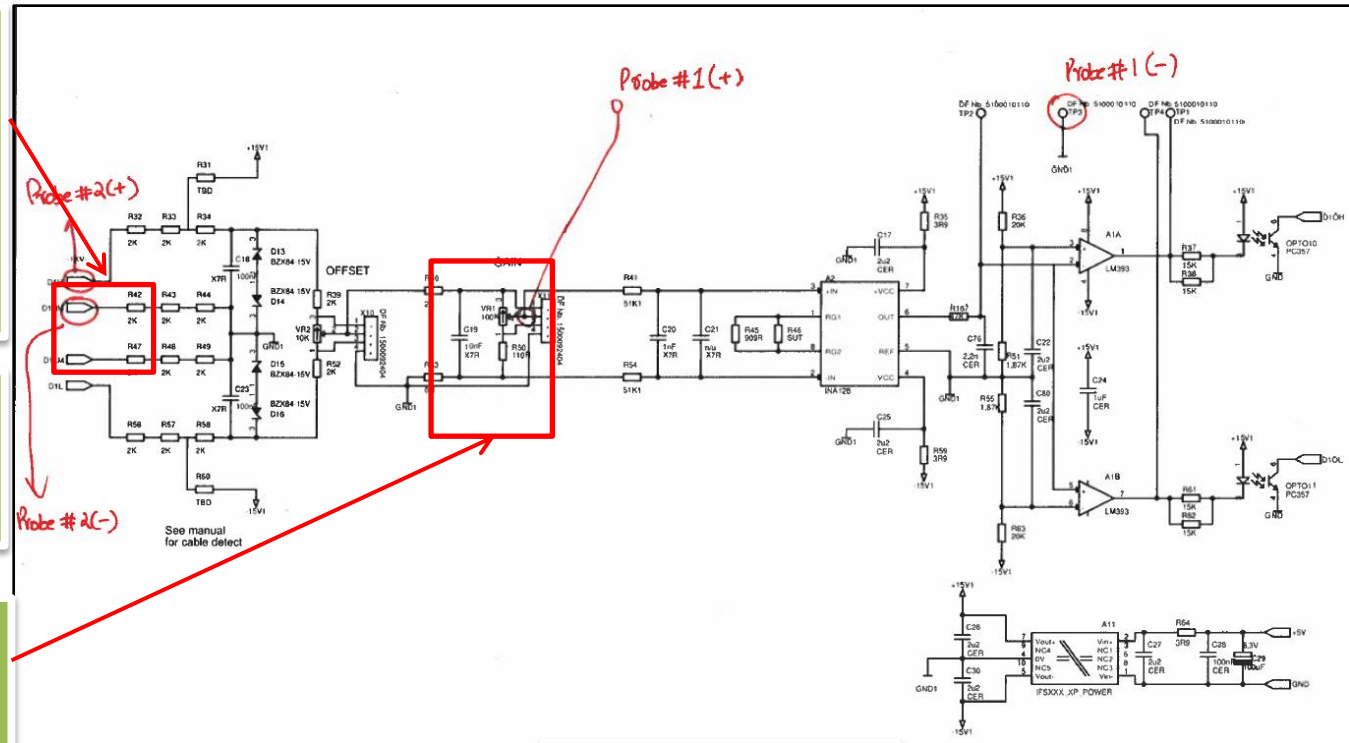

Electrical diagram

VII. Solenoid Quench Detection Issues: VT Values at initiation of Fast Dumps

| Fast Dump # | | | | | | | | | | | | | | | |
|------------------|---------------|------------|------------|-----------|-----------|-----------------|-------------|-------------|---|------------|-----------|-------------|-------------|---|--|
| Voltage Tap [mV] | 1 | 2 | 3 | 4 | 5 | 6 | 7 | 8 | 9 | 10 | 11 | 12 | 13 | 14 | |
| | Commissioning | | | | | Engineering Run | | | | | | Physics Run | | | |
| | 9/12/2017 | 9/12/2017 | 9/13/2017 | 9/15/2017 | 9/15/2017 | 12/12/2017 | 12/13/2017 | 12/14/2017 | 12/16/2017 | 12/18/2017 | 1/23/2018 | 2/19/2018 | 4/1/2018 | 4/9/2018 | |
| | 14:47 | 17:27 | 16:15 | 9:07 | 11:39 | 22:02 | 9:49 | 14:13 | 10:35 | 9:01 | 23:54 | 15:47 | 7:08 | 1:26 | |
| VT 1 | 14.912 | 13.294 | 13.660 | 16.891 | 14.26 | 12.695 | 12.207 | 11.230 | N O F a v o r a b l e d a t a | 18.555 | -42.480 | 36.621 | 34.668 | N O F a v o r a b l e d a t a | |
| VT 2 | -1.278 | 1.390 | -1.520 | 0.856 | 2.441 | 0.000 | -0.488 | 0.000 | | 1.465 | -1.465 | -0.488 | 0.000 | | |
| VT 3 | 0.641 | 1.209 | -1.417 | 1.215 | 2.441 | -0.488 | 1.953 | 1.953 | | 1.953 | 0.000 | -1.465 | 1.953 | | |
| VT 4 | -0.742 | -0.786 | -1.253 | 0.204 | 1.953 | -2.441 | -3.906 | -0.977 | | -2.930 | -1.953 | -3.418 | -3.906 | | |
| VT 5 | 6.926 | 8.583 | 6.195 | 5.556 | 4.395 | 6.348 | 8.301 | 9.277 | | 3.906 | 7.324 | 10.742 | 15.137 | | |
| VT 6 | -42458.267 | -43389.816 | -46558.030 | 380.821 | 673.828 | 9.766 | -53154.297 | -52285.156 | | -830.078 | -19.531 | -101230.469 | -99550.781 | | |
| VT 7 | 1.717 | 5.411 | -1.905 | 2.634 | 5.859 | 0.488 | 3.418 | 0.488 | | 0.488 | -1.953 | 4.395 | 1.465 | | |
| VT 8 | -55346.260 | -56415.939 | -60386.467 | 464.439 | 1630.859 | 29.297 | -70478.516 | -69423.828 | | -1064.453 | 0.000 | -151738.281 | -152695.312 | | |
| VT 9 | 2.926 | 2.306 | 5.928 | 6.395 | -20.508 | 4.883 | 4.395 | 2.930 | | 2.930 | 4.883 | 3.418 | 3.418 | | |
| VT 10 | 1200.628 | -12943.316 | -2310.753 | -98.467 | 1818.848 | 12.207 | 1354.980 | 1354.980 | | 36.621 | 12.207 | 4187.012 | 4199.219 | | |
| VT 11 | 4.290 | 4.728 | 4.040 | 0.755 | -0.977 | 0.488 | 4.395 | 2.441 | | 0.488 | 1.465 | 7.812 | 4.883 | | |
| VT 12 | -55308.800 | -56240.845 | -60315.140 | 522.919 | -1367.188 | 0.000 | -70419.922 | -69365.234 | | -1093.750 | 19.531 | -150117.188 | -152792.969 | | |
| VT 13 | 1.036 | 0.410 | -0.853 | 1.036 | 9.277 | -0.977 | -0.977 | 0.977 | | 2.441 | -3.418 | 0.000 | -1.953 | | |
| VT 14 | -42413.254 | -43245.964 | -46468.124 | 373.878 | -1015.625 | 0.000 | -53466.797 | -52226.562 | | -839.844 | 0.000 | -101699.219 | -97968.750 | | |
| VT 15 | 1.093 | -2.508 | -3.763 | 1.575 | -0.488 | -0.488 | -1.465 | -6.836 | | 0.000 | -0.977 | -0.977 | -2.441 | | |
| VT 16 | 1.936 | 0.240 | 2.125 | 1.724 | 0.977 | -0.488 | 3.906 | -0.488 | | -0.977 | 0.000 | 3.418 | 0.488 | | |
| VT 17 | -0.956 | 1.799 | 3.487 | -0.601 | -0.977 | 2.441 | 1.465 | 0.000 | | 1.953 | 0.000 | 1.465 | 2.441 | | |
| VT 18 | -1.122 | -2.817 | -0.012 | -2.552 | -2.930 | -3.418 | -1.465 | -0.488 | | -2.441 | -2.930 | -0.977 | -1.465 | | |
| VT 19 | 13.872 | 18.810 | 18.686 | 18.583 | 20.508 | 10.742 | 16.113 | 12.207 | | 21.484 | -70.312 | 68.359 | 63.477 | | |
| VT 20 | -200542.908 | 2468.872 | 2293.549 | 1595.001 | 1562.500 | -78.125 | -252578.125 | -246875.000 | | -3906.250 | -234.375 | -513984.375 | -512890.625 | | |
| VT 21 | 312.288 | 335.794 | 339.346 | 341.055 | 342.773 | 379.395 | 371.582 | 365.723 | | 447.754 | -469.727 | 644.043 | 641.113 | | |

- VT values in this table taken *at the trip time* (based on PLC and SOE timestamps)
- Voltage values of suspected VT18 and VT2 do not seem to be high because their spikes occur ~ 200 ms before trip. New table in progress

VIII Solenoid/ Torus CMS- Spares

- Made spares list for critical components of cRIO and PLC
 - Currently there is not PLC controller spares available.
 - Only five Control Logix PLC modules available.
 - 1756-OW16I Relay module (x3)
 - 1756-OF8 V/I AO module (x1)
 - 1734-IB4 Point IO DC module (x1) (Only to be use as Torus spare)
 - Currently there is not a reliable spare cRIO controller
 - Ordered a NI cRIO-9045 controller to be used as spare ether for solenoid or torus Fast DAQ.
 - Five cRIO spare modules available
 - NI-9239 ADC input module (x4)
 - At this time modules installed and running at the Solenoid and Torus FastDaq cRIO chassis.
 - NI-9870 RS232 Serial interface module (x1)

IX. Summer tasks

1. Update four cRIO controllers to LabVIEW 2017 (Includes Hall B PCs)
2. Update firmware of CryoCon units for the Torus
3. Verify and test variables that could be contributing to QDtrips (VT2 and VT18)
4. Hardware/software filters for Fast DAQ data
5. Grounding/wiring of power source connected to all related controls
6. Change VT panel switches

IX. Summer task

7. Add relay to E-Stops on PSU and remote control crate to generate fast dump
8. Implement Sequence of Event (SOE) timestamps EPICS screen
9. Evaluate recovery procedure of cryogen due to loss of flow from ESR
10. Reduce electronic noise
11. Connect Hall B backup power for vacuum pumps
12. Check leaks on electric valves
13. Complete checking of all drawings and upload to document repository

X. Conclusions

- Torus is in good health
- Solenoid is in fair health
 - Must solve voltage tap issues, which has been cause of most trips